

AC POWER GUIDELINES

The Illusion preamplifier has superb regulation and does not require a dedicated AC circuit. Avoid connections through extension cords or multiple AC adapters. High quality 15 amp AC strips are acceptable. The use of AC line conditioning devices is not recommended. The features provided by these devices are already included in the Illusion.

Connecting the Illusion to Your System

Krell recommends using its proprietary Krell CAST system for unparalleled sonic performance for connections between the preamplifier and other CAST-equipped components. Krell CAST uses flexible interconnecting cables that can be drawn through tight spaces and concealed. The Illusion also offers balanced operation. This not only minimizes sonic loss but is also immune to induced noise, especially for installations using long cables.

Position the preamplifier and power supply where you intend to use them in your system. Do not move the chassis after they are connected.

1. Connect the power supply chassis and the preamplifier chassis with the 12-pin DC cable provided, using the back panel DC power connectors (25).
2. Neatly arrange and organize wiring to and from the preamplifier and all components. Separate the AC wires from any audio cables to prevent hum or other unwanted noise from being introduced into the system.
3. Connect the outputs of your source equipment to the appropriate CAST (18), balanced (15), single-ended (16), or tape inputs (17) on the Illusion.
4. Connect the main outputs (20) on the Illusion to your amplifier's inputs.
5. Connect the supplied AC power cord to the IEC power cord receptacle (28) of the power supply unit.
6. Plug the other end of the AC power cord into AC power and turn on the main power switch (30). The display (3) scrolls through ILLUSION SOFTWARE VERSION, and the stand-by/power LED (7) illuminates red on the preamplifier and green on the power supply, indicating that the Illusion is in stand-by mode. When the scrolling stops, the Illusion is ready to be powered on.

Note

Use only the power cord provided with the Illusion to make the connection to AC power. Operation with a power cord other than the one supplied by Krell can induce noise, limit current, or otherwise impair the ability of the preamplifier to perform optimally.

Operating the Illusion

After the Illusion is connected to your system and to AC power, and the front panel display has stopped scrolling, begin operation:

1. Press the power button (1) on the front panel, or the remote control power key. The standby/power LED turns blue. The display shows the factory default input: S-1, and level: 000. The Illusion is now in the operational mode.
2. With the preamplifier output muted, or the volume fully attenuated, select a source manually using the front panel input select buttons (8, 9, or 10) or the remote input select keys. Start playing the source. Use the level control knob (14) or the remote level keys to set the volume to a comfortable level.
3. To return the preamplifier to the stand-by mode, press the power button (1) or remote power key. (We recommend leaving the Illusion in the stand-by mode when it is not playing music.)

Channel Balance Adjustment

The balance function allows adjustment of the left and right balance. The options are: CENTER, L .5-5 dB <, R .5-5 dB >.

1. Press the preamplifier's menu button (5), then use the level control knob, to select: BALANCE.
2. Press the enter button (6). The display shows the default mode: CENTER.
3. Use the level control knob to select the desired balance option from .5 to +5 dB in .5 dB increments, left or right.
4. Press the enter button to confirm the selection. The display reads: BALANCE. Press the MENU button to return to normal operation.
5. The balance can also be adjusted directly using BAL L and BAL R keys on the remote control.

Illusion Preamplifier

MODEL

SERIAL NUMBER

SETUP GUIDE

Getting Started

Thank you for your purchase of the Krell Illusion preamplifier. The Illusion features Krell Current Mode circuit topologies, Krell CAST technology, and a powerful, separate power supply for exceptional audio performance. A thoughtful suite of menu options ensures that the Illusion can be customized for the greatest ease of operation. Please contact your authorized dealer, distributor, or Krell if you have any questions not addressed in the owner's reference.

Overview

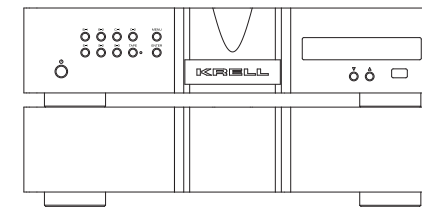

The Illusion is comprised of two chassis: the preamplifier chassis and the power supply chassis.

The preamplifier's front panel provides power on, input selection, level control, menu functions, and status display. The rear panel allows connection to audio sources, power amplifiers and other system components.

The power supply unit contains powerful transformers, high quality regulators, and extensive electrical and magnetic shielding, supplying optimum regulated DC power to the preamplifier.

The remote control provides power, preamplifier, level control, navigation and customization functions, CD and DVD player controls and menu configuration.

WARNINGS



This product complies with the EMC directive (89/336/EEC) and the low-voltage directive (73/23/EEC).

This CLASS 1 apparatus must be connected to a MAINS socket outlet with a protective earthing connection.

Do not place the preamplifier where it could be exposed to dripping or splashing.

Do not remove or bypass the ground pin on the end of the AC cord. This may cause radio frequency interference (RFI) to be introduced into your playback system.

The ventilation slots on the top and bottom of the preamplifier must be unobstructed at all times during operation. Do not place flammable material on top of or beneath the component.

Turn off all systems' power before connecting the preamplifier to any component.

Make sure all cable terminations are of the highest quality, free from frayed ends, short circuits, or cold solder joints.

THERE ARE NO USER-SERVICEABLE PARTS INSIDE ANY KRELL PRODUCT.

Unpacking

Note

Save all packing materials. If you need to ship the Illusion in the future, repack the unit in its original packaging to prevent shipping damage.

1. Open the shipping box and remove the top layer of foam. You will see these items:

| | |
|---------------------------------|-------------------------------|
| 1 Preamplifier chassis | 1 Remote control |
| 1 Power supply chassis | 2 AAA remote batteries |
| 1 IEC connector (AC power) cord | 1 T-10 Torx wrench for remote |
| 1 12-pin DC supply cable | 1 Owner's reference |

2. Carefully remove all items from the shipping box.
3. Place the preamplifier and power supply in a safe location and remove the protective plastic wrapping.

Placement

We recommend placing the preamplifier on top of the power supply unit. Place them on a firm, level surface, away from excessive heat, humidity, or moisture. The preamplifier requires at least two inches (5 cm) of clearance on each side and at least two inches (5 cm) of clearance above to provide adequate ventilation. Installations inside cabinetry may need extra ventilation.

Figure 1 The Illusion Front Panel

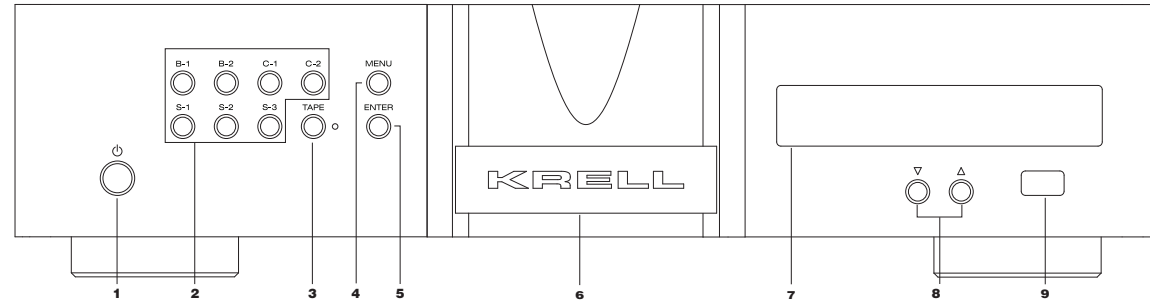

Front Panel

- 1 Power**
Use this to switch the preamplifier between stand-by and operational modes.
- 2 Input selectors**
Use these to select the corresponding rear panel input that is connected to a single-ended (S-1, S-2, S-3), balanced (B-1, B-2), or CAST (C-1, C-2) analog source. The display (7) shows the selected input and volume level.
- 3 Tape input selector**
Use this to select the tape input that is connected to an analog tape source. The blue LED illuminates when the tape input is selected. The display (7) shows: TAPE and the main volume level.
- 4 Menu button**
Use this to access the menu functions of the Illusion.
- 5 Enter button**
Use this to configure the menu functions of the Illusion. See Menu (4).
- 6 Stand-by/Power Indicator**
The power indicator illuminates red (stand-by) when the Illusion is plugged into a standard AC wall receptacle. The power indicator illuminate blue (operational mode) when the power button (1) is pressed while the Illusion is in stand-by mode.

- 7 Display**
This provides channel status messages, including input selection, volume level, balance offset, and menu selections.
- 8 Level control buttons**
Use these buttons to increase or decrease system volume level. The level control buttons or keys also select menu options that customize the Illusion.
- 9 Infrared sensor**
This receives commands from the remote control. Make sure this is not obstructed.

Figure 3 The Illusion Back Panel

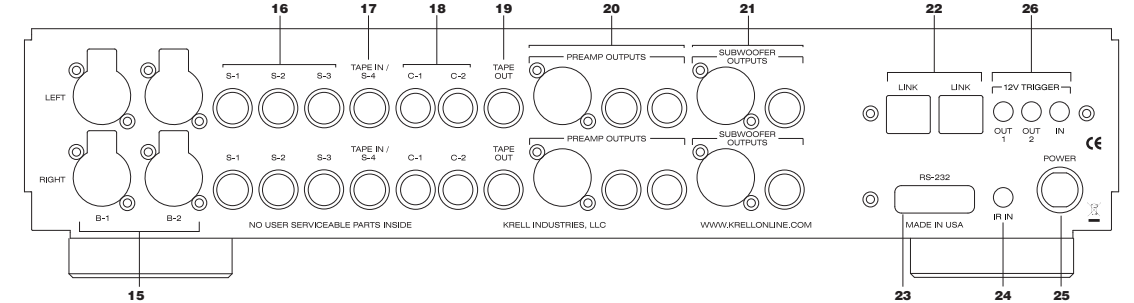

Back Panel

- 15 Balanced inputs: B-1 and B-2**
These XLR balanced analog source input connectors are wired as follows:
Pin 1 Ground
Pin 2 Non-inverting
Pin 3 Inverting
- 16 Single-ended inputs: S-1, S-2, and S-3**
There are 3 single-ended analog source inputs with RCA connector pairs.
- 17 Tape input**
This single-ended input pair is for use with a tape source.
- 18 C-1 and C-2 inputs**
The two CAST inputs have 4-pin bayonet connectors, for use with Krell CAST-equipped input devices.
- 19 Tape output**
This single-ended output pair is used for recording the selected input source.
- 20 Main outputs**
The Illusion is equipped with one balanced XLR output pair, one single-ended RCA output pair, and two CAST output pairs with 4-pin bayonet connectors (for use with Krell CAST-equipped amplifiers).
- 21 Subwoofer**
The Illusion is equipped with one balanced XLR and one single-ended RCA subwoofer output pair. Note: These outputs are only active when the Illusion is equipped with the optional crossover board.
- 22 CAN link**
These RJ-45 link connectors are connected in parallel. They are used to operate preamplifier channels in linked mode.
- 23 RS-232 port**
This port receives messages from a computer-based control system, providing integrated control of all preamplifier functions.
- 24 RC-5 in**
This remote connector is used with third-party remote control systems that provide RC-5 (IR) data via a wired connection. A stereo tip, ring, sleeve 1/8" mini connector is used in the following configuration:
Tip = RC-5 data
Ring = +5 V
Sleeve = GND.
- 25 DC power connector**
Use the supplied 12-pin cable to connect this to the corresponding DC power connector on the power supply. Make sure the AC power cord is unplugged before making any connections to the preamplifier.
- 26 12 VDC in/out (12 V trigger)**
There are 2 outputs and one input that send and receive 12 VDC power on/off (trigger) signals to and from other Krell components, and other devices that incorporate a 12 V trigger. This allows other components to be turned on/off, or to/from stand-by, through the remote control.

Remote Control

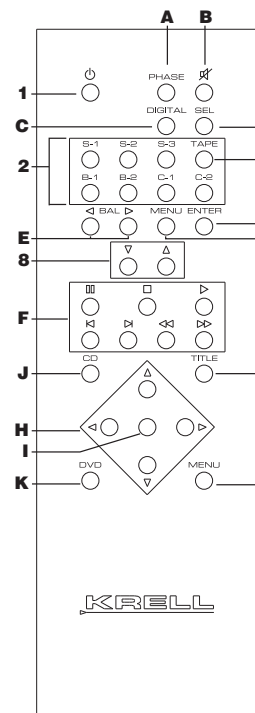

Figure 2 The Remote Control

- Keys labeled 1 to 9**
have the same function (and callout number) as the front panel controls.
 - Keys labeled A through L**
are unique to the re-remote control
 - A Phase button**
Use this to invert the absolute polarity of the main output.
 - B Mute button**
Use this to mute the preamplifier output. To unmute, press the mute button again.
 - C Digital button**
Unused
 - D Sel(ect) button**
Unused
 - E Bal(ance) keys**
Use to balance left and right output levels.
 - F Transport keys**
These keys are functional with all Krell CD and DVD players.
 - G Menu key**
Use this to enter CD or DVD player menus.
 - H Direction keys**
Use these keys to navigate CD and DVD menus.
 - I Select key**
Use this to make selections from CD and DVD menus.
 - J CD key**
Press this to make the transport keys operate Krell CD players.
 - K DVD key**
Press this to make the transport keys operate DVD players.
 - L Title key**
Use this with CD or DVD player menus.
- Note**
Use the supplied Torx wrench to remove the battery panel, then install the included AAA batteries.

Figure 4 The Illusion Power Supply



Power Supply

- 27 Fuses**
Always unplug the power cord before inspecting these fuses. Always replace the fuses with the exact style and rating.
- 28 IEC power cord receptacle**
This is for use with the provided AC power cord. Plug the other end into an AC Mains supply capable of supplying the correct AC voltage and current for the power supply.
- 29 Phono power port**
This is for connecting the preamplifier to a Krell KPE phono stage. See the KPE owner's reference for more details.
- 30 DC power connector**
Use the supplied 12-pin cable to connect this to the corresponding DC power connector on the preamplifier. Make sure the AC power cord is unplugged before making any connections to the preamplifier.
- 31 Main Power Switch**
Press the "1" to put the preamp in the standby mode. Press the "0" to power the preamplifier off completely. The switch should remain unobstructed for ease of operation and in case of an emergency.